

■ 金属膜电阻器
Metal Film Resistor

◆ 特征
Features

- * 阻值范围宽、温度系数小、使用范围广
Wide resistance range, small temperature coefficient, wide application range.
- * 环保无铅产品
RoHS compliant / lead-free available.

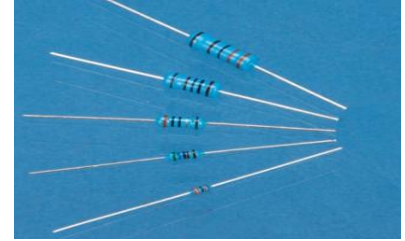

◆ 应用
Application

- * 适用于各种交、直流电子电路，各种精密仪器仪表中
Suitable for various AC and DC electronic circuits and various precision instruments

◆ 型号表示法
Part Number

- * 依据其种类，分别标明型号、额定功耗、标称阻值、精度、和形状。
According to the types of power rated, resistor value, tolerance and shapes.

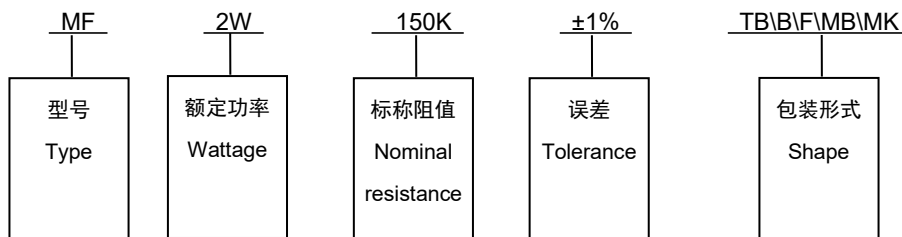

◆ 金属膜电阻器结构图
Metal Film Construction

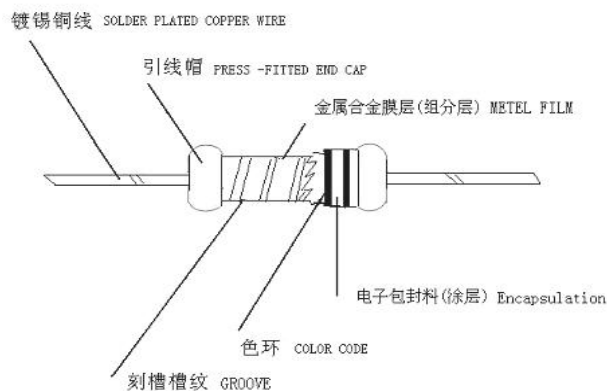

备注 REMARK: 底漆颜色 COATING COLOR: 兰色 BLUE

◆ 特点
Features

- * 高精度的产品
Tor quality and high reliability .

- * 低电流噪声 (小于 0.2UV)
Low noise (<0.2UV)
- * 低电阻温度系数
($\pm 50\text{PPM}$ /只适应 $<10\text{R}<\text{R}<1\text{M}$) LOW T.C.R TO
- * 极好的长期稳定性
Excellent long term stability.
- * 标准误差: $\pm 0.1\%, \pm 0.25\%, \pm 0.5\%, \pm 1\%$. (阻值 $1\text{M}\leq\text{R}<1\text{R}$ 生产实际控制在 $\pm 2\%$ 以下)
Standard tolerances : $\pm 0.1\%, \pm 0.25\%, \pm 0.5\%, \pm 1\%$ (The resistance value of $1\text{M}\leq\text{R}<1\text{R}$ is controlled below $\pm 2\%$ in actual production)
- * 环保无铅产品
RoHS compliant/lead-free available.

◆ **主要技术指标**
Main Specification

注: “S”代表体积小小型化, “S”采用 85%含铅量材料

型号 Type	最大工作电压 MAX WORKING	最大负荷电压 MAX OVERLOAD	额定功率Rated Power at 70°C	电阻范围 RESISTANCE VALUE RANGE	绝缘耐压 Dielectric withstanding
MF 1/6W / 1/8W	200V	400V	1/6W	0.1Ω—1MΩ	300V
MF1/4W / 1/4W S	250V	500V	1/4W	0.1Ω—10MΩ	350V
MF1/2W / 1/2W S	350V	700V	1/2W	0.1Ω—10MΩ	350V
MF1W / 1W S	500V	800V	1W	0.1Ω—10MΩ	500V
MF2W / 2W S	700V	1000V	2W	0.1Ω—10MΩ	500V
MF3W / 3W S	800V	1200V	3W	0.1Ω—10MΩ	500V
MF5W/5W S	550V	1500V	5W	0.1Ω—10MΩ	500V

* **额定功率**
Power Rating

额定功率的定义为在环境温度 70°C 最大输出功率。当环境温度超过 70°C, 额定功率按下图曲线递减。

Power rating is defined as maximum power rating continuously applied under ambient temperature at 70°C. when the ambient temperature exceeds 70°C, The rated power decreases according to the curve below.

FIG.1 DERATING CURVE

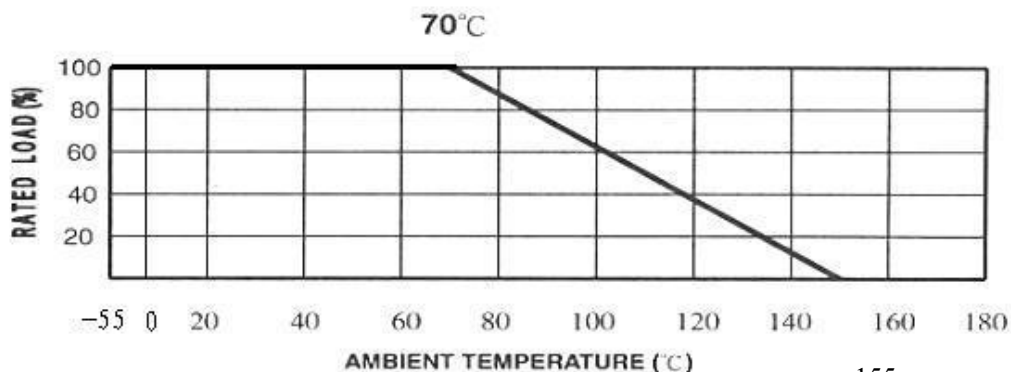

*** 额定电压**

Rated voltage

额定电压为交流或直流电压（频率为 50Hz 或 60Hz）额定电压计算方式为：

Rated voltage is defined as the DC or AC (effective Value at commercial frequency example 50 C/S,60 C/S), Voltage when rated power is applied and can be calculated

By the following:

$$V = \sqrt{P \times R}$$

V = RATED VOLTAGE

P = RATED POWER (WATTS)

R = NOMINAL RESISTANCE VALUE (OHM)

When the calculated rated voltage exceeds the Maximum usable voltage flue shown in CHART,the Maximum usable voltage is defined as the voltage According to the power-decreasing curve shown in CHART.

*** 产品性能**

Performance

项目 ITEM	性能及验收标准 PERFORMANCE AND QUALIITY ACCEPTANCE	测试方法(JIS C 5202) TEST METHOD(JIS-C 5202)
温度系数 Resistance to temperature coefficent	1. $10\Omega < R_x < 100K\Omega$ $PPM/^{\circ}C < 50PPM$ 2. $R_x < 10\Omega$ $PPM/^{\circ}C > 100PPM$ 3. $100K\Omega < R_x < 10M\Omega$ $PPM/^{\circ}C < 100PPM/^{\circ}C$	$PPM/^{\circ}C = \frac{R - R_0}{R_0} * \frac{10^6}{T - T_0}$ R = Measured resistance (Ω) at T T °C 电阻实测值 (Ω) Ro = Measured resistance (Ω) at To To °C 电阻实测值 (Ω) T = Measured test temperature(°C) 测试温度的实测值 To = Measured base temperature(°C) 基准温度的实测值
短时负荷 Short time overload	$\pm(0.25\%R + 0.05ohm)$ 无破损（外观正常） Shall be no mechanical breakage	2.5 倍额定电压（交流或直流），5 秒。 AC or DC voltage 2.5times the rated Voltage for 5 seconds .
耐电压 Voltage endurance	无击穿或飞弧 No breakdown or flashover	将电阻放于“V”形槽内，参照表一电压，保持一分钟。 Place the resistor in the "V" slot and hold for one minute, as shown in Table 1.
端子强度 Terminal strength	内外部无损伤 Shall be no mechanical breakage	施加 3.5KG 30S 的拉力 Pull test apply 3.5KG force to the lead in the direction of lead axis for 30±5 seconds.
耐焊性 Heat resistively against soldering	$\pm(0.5\%R + 0.05ohm)$ 无破损（外观正常） Shall be no mechanical breakage	将电阻引出端浸入 350°C ± 10°C 的锡中，深度离电阻体 3±0.05mm，时间 3.5±0.5 秒。放置一小时再测试。 Dip the lead in to a solder bath having a temperature of 350°C ± 10°C up to 3±0.05mm from the body of the resistor and hold it for 3.5±0.5seconds leave the resistor ,at room temperature 1 hours after ,then Measure.

寿命试验 Load life test	$\pm(1\%R + 0.5\text{ohm})$ 无破损（外观正常） Shall be no mechanical breakage	在 70℃ 的环境中施加额定电压，1.5 小时通，0.5 小时断 1000 小时。 In the constant temperature chamber 70℃, apply rated voltage for 1.5 hour and shut voltage for 0.5 hour and repeat this cycle for 1000 hours,
上锡效果 Solder ability	$\geq 95\%$	浸入 260℃ $\pm 5^\circ\text{C}$ 的锡槽中， 时间 5 ± 0.5 秒。 Dip the lead in to a solder bath having a temperature of 260℃ $\pm 5^\circ\text{C}$. Time: 5 ± 0.5 seconds.
湿度负荷试验 Humidity load test	$\leq \pm(2\% R + 0.1\text{ohm})$ 无破损（外观正常） Shall be no mechanical breakage	温度在 40℃ $\pm 2^\circ\text{C}$ ，相对湿度 90 - 95% 室内，用额定电压 1.5 小时开和关闭电压 0.5 小时，重复这个周期 1000 小时，离开 1 小时后在室温下测试。 In temperature chamber 40℃ $\pm 2^\circ\text{C}$ ， relative humidity 90 - 95%, Apply rated voltage 1.5 hour and shut voltage 0.5 hour repeat this cycle for 1000 hours, leave in room temperature for 1 hour after test,
耐振性 Vibration	无破损（外观正常） Shall be no mechanical breakage	设置振动频率在 10HZ - 55HZ 10HZ/秒 1.5mm 的幅度，在 1 分钟更换频率的。振动三个方向，在 3 小时内完成。
上限类别温度耐久性 Endurance at upper-limit temperature	$\leq \pm(2\%R + 0.1\Omega)$	在 125℃ 温度下，持续时间 1000H At 125 °C temperature, duration of 1000h

* 标示

Marking

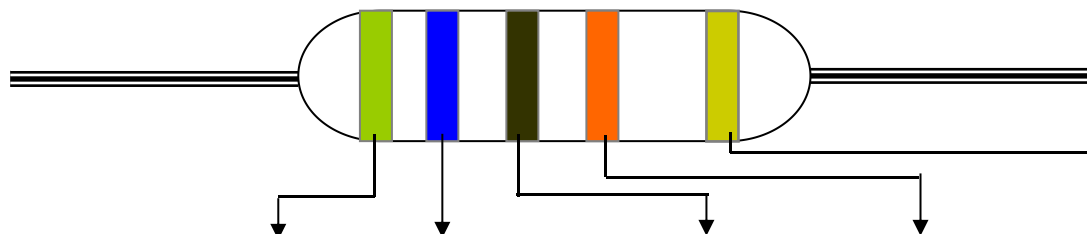

Color	1 st Band	2 nd Band	3 rd Band	4 th Band	Tolerance
Black 黑	0	0	0	10 ⁰	
Brown 棕	1	1	1	10 ¹	$\pm 1\%$ (F)
Red 红	2	2	2	10 ²	$\pm 2\%$ (G)
Orange 橙	3	3	3	10 ³	
Yellow 黄	4	4	4	10 ⁴	
Green 绿	5	5	5	10 ⁵	$\pm 0.5\%$ (D)
Blue 蓝	6	6	6	10 ⁶	$\pm 0.25\%$ (C)
Violet 紫	7	7	7	10 ⁷	$\pm 0.1\%$ (B)
Grey 灰	8	8	8	10 ⁸	$\pm 0.05\%$ (A)
White 白	9	9	9	10 ⁹	
Gold 金				10 ⁻¹	$\pm 5\%$ (J)
Silver 银				10 ⁻²	$\pm 10\%$ (K)

* B 型尺寸

Dimension (B)

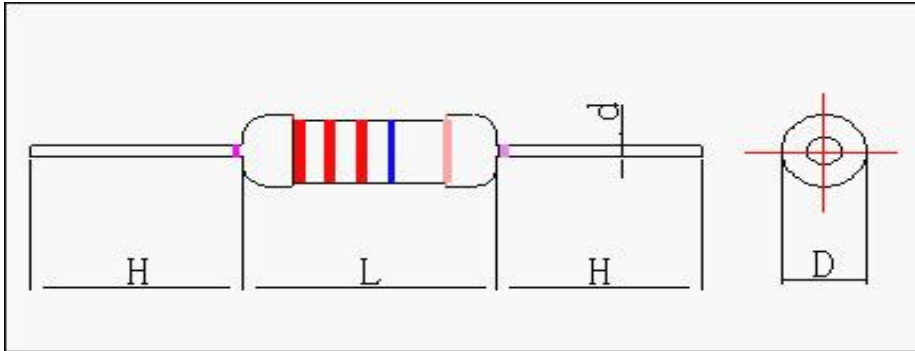

Unit: m/m

TYPE		L	D	H	d	PULLING(Kg)
1/6W / 1/8W / 1/4WS	T52	3.2±0.3	1.8±0.3	28±2.0	0.40±0.05	2.5Kg-30S
1/4W / 1/2WS	T52	6.0±0.5	2.3±0.3	27±2.0	0.45±0.05	2.5Kg-30S
1/2W / 1WS	T52	9.0±1.0	3.5±0.5	26±2.0	0.56±0.05	2.5Kg-30S
1W / 2WS	T52	11.0±1.0	4.5±0.5	25±2.0	0.65±0.05	3Kg-30S
	T63	11.0±1.0	4.5±0.5	31±2.0	0.65±0.05	3Kg-30S
	T73	11.0±1.0	4.5±0.5	34±2.0	0.65±0.05	3Kg-30S
2W / 3WS	T63	15.0±1.0	5.0±0.5	29±2.0	0.70±0.05	5Kg-30S
	T73	15.0±1.0	5.0±0.5	33±2.0	0.70±0.05	5Kg-30S
3W / 5WS	T63	17.0±1.0	6.0±0.5	27±2.0	0.70±0.05	5Kg-30S
	T73	17.0±1.0	6.0±0.5	32±2.0	0.70±0.05	5Kg-30S
5W		24.0±1.0	8.0±1.0	28±2.0	0.75±0.05	5Kg-30S

* 编带尺寸

Taping Dimension (TB)

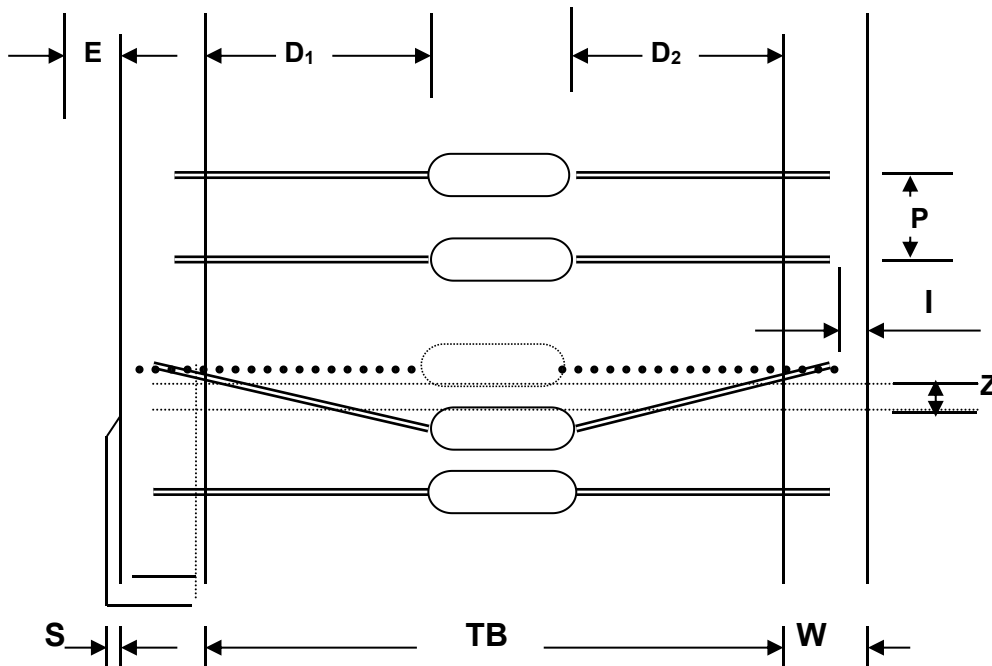

Unit: m/m

WATTS	Type	TB	P±0.5	W±0.5	(D1-D2) MAX	E MAX	Z MAX	S MAX	(l) MAX
1/6W/ 1/8W 1/4WS	T 52	52±1.5	5	6	0.8	0	1.2	0.8	3.2
1/4W / 1/2WS	T 52	52±1.5	5	6	0.8	0	1.2	0.8	3.2
1/2W / 1WS	T 52	52±1.5	5	6	0.8	0	1.2	0.8	3.2
1W / 2WS	T52	52±1.5	5	6	0.8	0	1.4	0.8	3.2
	T 63	63±1.5	5	6	0.8	0	1.4	0.8	3.2
	T 73	73±1.5	5	6	0.8	0	1.4	0.8	3.2
2W / 3WS	T63	63±1.5	5	6	0.8	0	1.4	0.8	3.2
	T 73	73±1.5	5	6	0.8	0	1.4	0.8	3.2
3W / 5WS	T 73	73±1.5	10	6	0.8	0	1.4	0.8	3.2
	T63	63±1.5	5	6	0.8	0	1.4	0.8	3.2
5W	T 73	73±1.5	10	6	0.8	0	1.4	0.8	3.2

*** 包装**

Packing

• 标签规格 LABEL SPECIFICATION

- a. 型号及功率 TYPE、WATTS
- b. 电阻值和误差 RESISTOR VALUE AND TOLERANCE
- c. 数量 QUANTITY
- d. 生产批号 LOT NO.

• 包装数量

Packing quantity

Unit: BOX / Kpcs

TYPE QTY	1/8W	1/4W	1/2W	1W	2W	3W	5W
	T26	5	5	NA	NA	NA	NA
T52	5	5	2.5	1	NA	NA	NA
T63	NA	NA	NA	1	1	0.5	0.25
T73	NA	NA	NA	1	1	0.5	0.25
B	20	10	5	4	3	2	1
F	20	10	5	4	3	2	1
M	20	10	5	4	3	2	1
MB	NA	NA	NA	4	3	2	1
MK	NA	NA	NA	4	3	2	1

◆ 附加说明:

Additional instructions:

* 产品存放条件

Product storage conditions

a 电阻器应存放在干燥、通风的环境条件下，产品不得受阳光直接照射；

Resistor should be stored in dry and ventilated environment conditions, the product shall not be affected by direct sunlight;

b 电阻器存放环境应无酸、碱、硫化等具有腐蚀气氛的环境中；

Resistor to deposit environment should be no acid, alkali corrosion, sulfide, etc have atmosphere environment;

c 产品存储时间不得超过两年。

Product storage time may not exceed two years .

* 产品使用补充说明

Products use added

a 产品功率负荷，遵循额定功率降功耗曲线负荷；

Product power load, follow the rated power drop curve of load power consumption;

b 工作电压按额定电压计算公式计算：

Working voltage according to the rated voltage calculation formula:

$$V = \sqrt{P \times R}$$

式中：

V =额定电压（伏特） rated voltage (volt)

P =额定功率(瓦特) rated power (watts)

R =标称电阻值(欧姆) nominal resistance (ohms)